

- Table of Contents -

1.	General	1
2.	Product Series	2
3.	Classification of Gold Capacitors	3
4.	Applicable Fields for Gold Capacitors	4
5.	Construction	5
6.	Practical Circuits for Golden Capacitors	6 ~ 10
7.	Equivalent Circuit Model of Gold Capacitors	11 ~ 16
8.	Property of Capacitance	17 ~ 21
9.	Leakage Current	22 ~ 23
10.	Voltage Holding Characteristic	24 ~ 27

1. General

The Gold Capacitors are electric double-layer **capacitors** using organic electrolyte, which were successfully developed as commercial products for the first time in the world. Farad order of capacitance can be obtained utilizing the surface area of active carbon.

Gold Capacitors were first employed for power failure backup in the programmable timers for the Panasonic video tape recorders in 1978. Since then their application has been expanding to wider business fields from consumer use to industrial use with the development of a variety of product types.

Gold Capacitors are of such a special type obtained by forming electric double layers on an active carbon surface that they have different properties from ordinary capacitors. So, a brief explanation on the product and its theoretical background will be given in the following, using the data obtained through over 10 years research and development made by the Company Research Laboratory and the Capacitor Division.

We shall be pleased if this material is helpful for you to deepen your understanding of Gold Capacitors and can be a useful reference in using them for your design.

2. Product Series

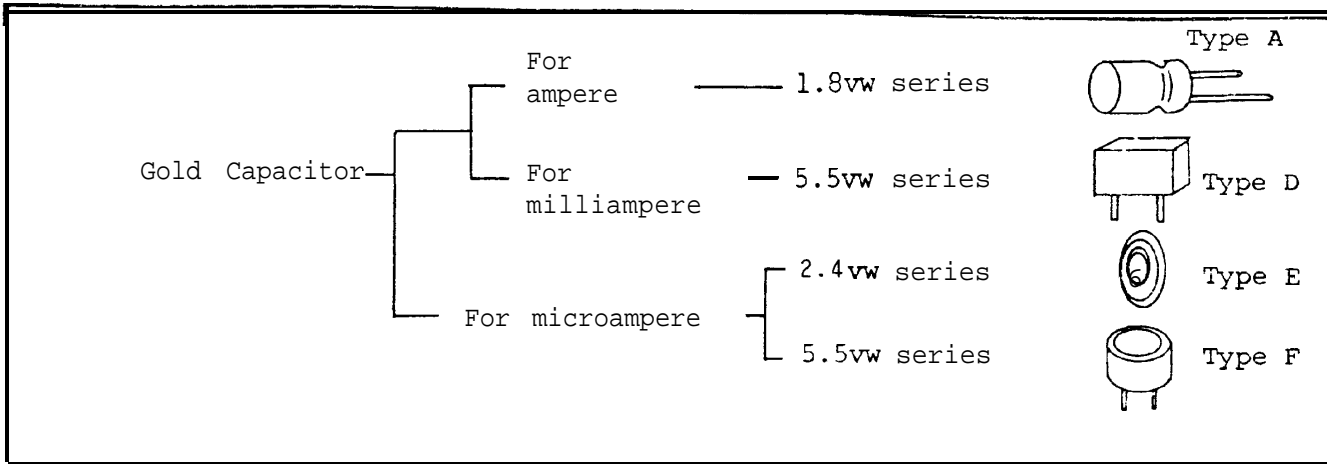

(F)		0.01	0.022	0.033	0.047	0.1	0.15	0.33	0.47	1	1.5	3.3	4.7	6.8	10
		.8 V					○		○		○		○	○	○
2.4 V	E						○				○				
5.5 V	D					○		○		○		○			
	F	○	○	○	○	○		○	○						

3. Classification of Gold Capacitors

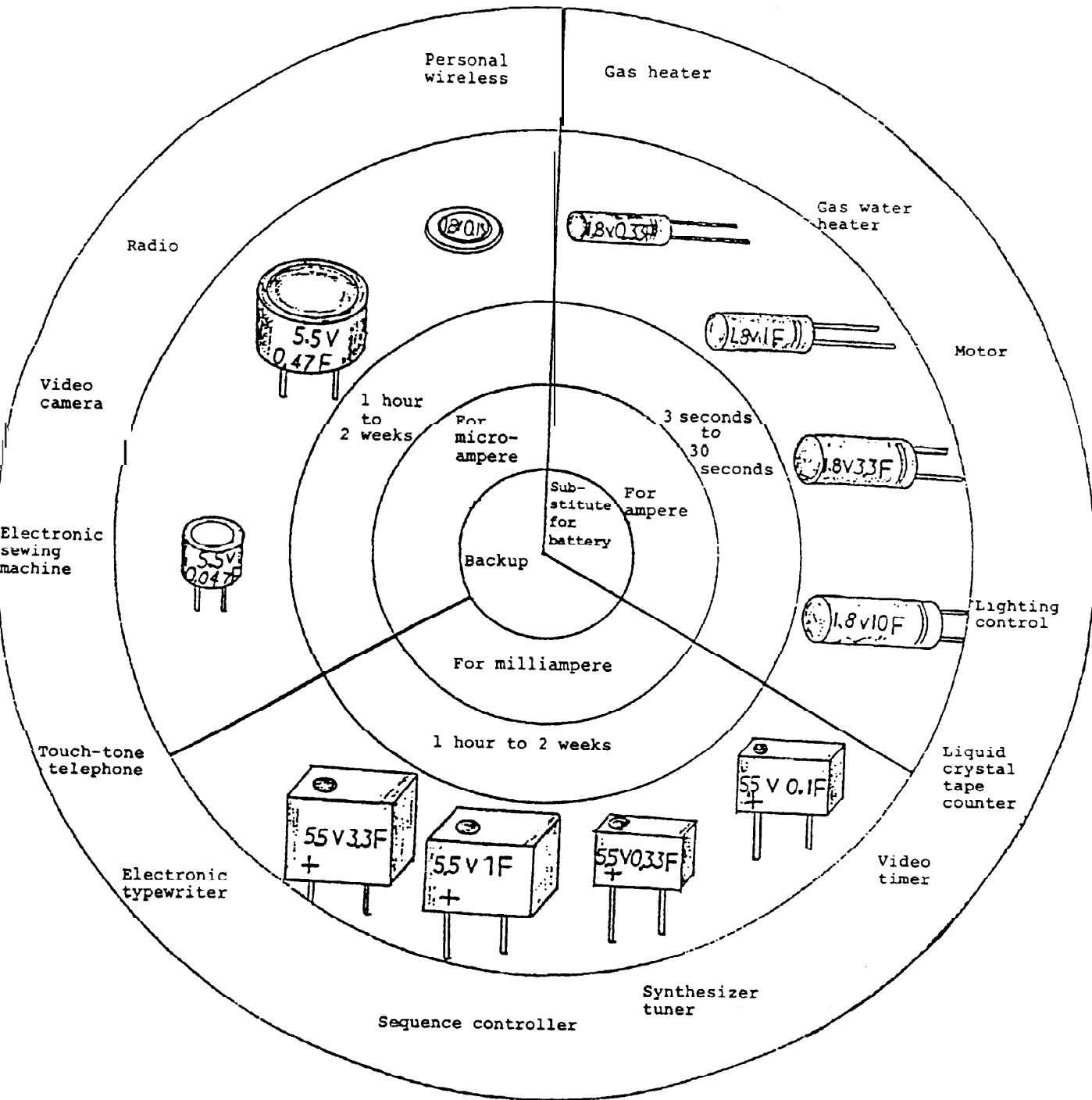

4. Applicable Fields for Gold Capacitors

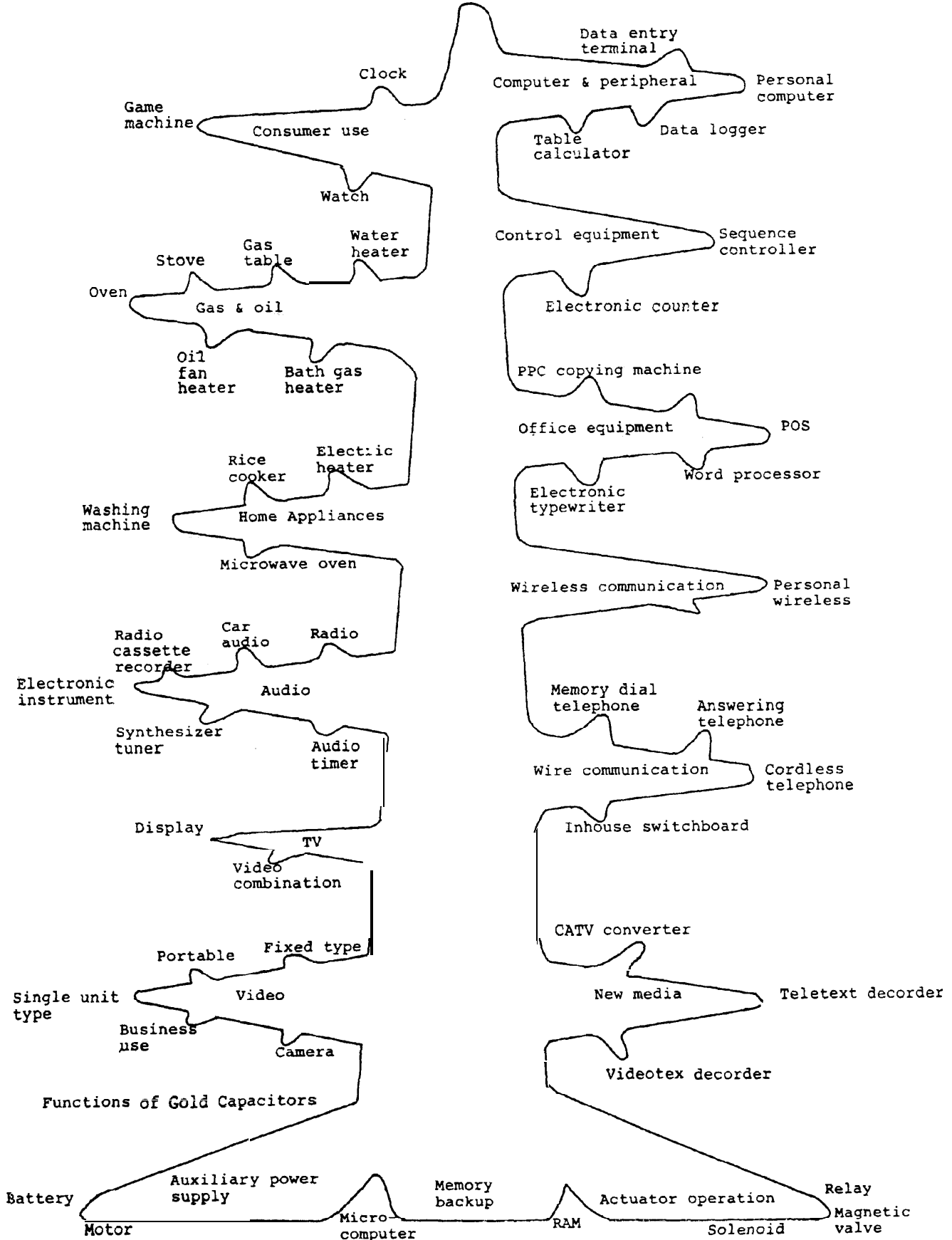

5. Construction

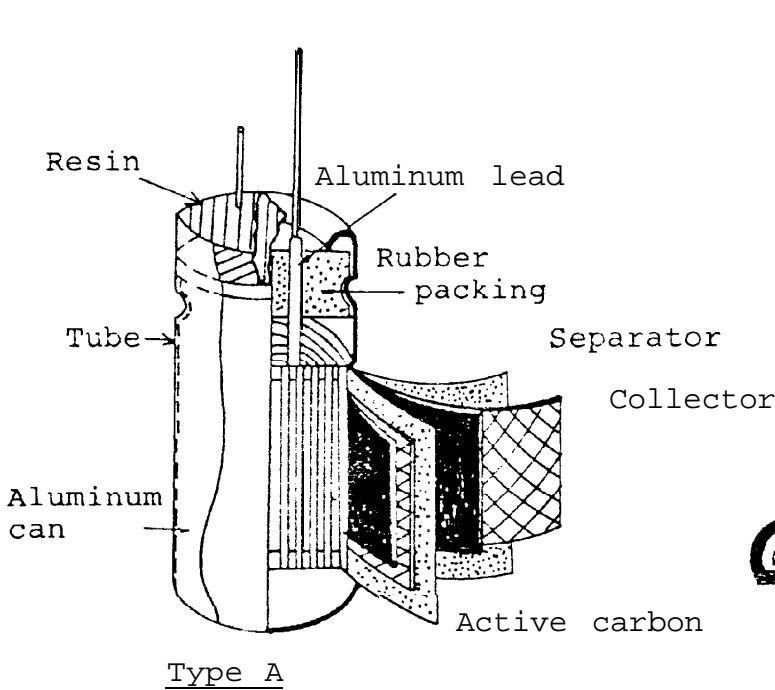

Type A

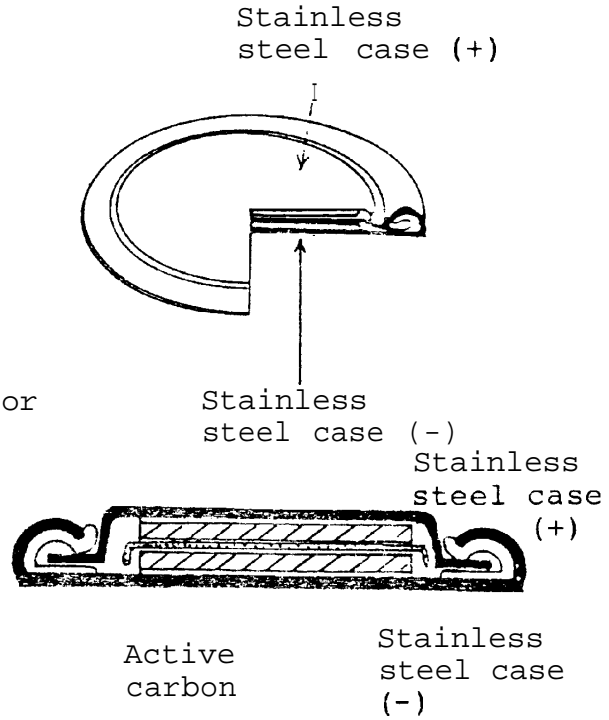

Type E

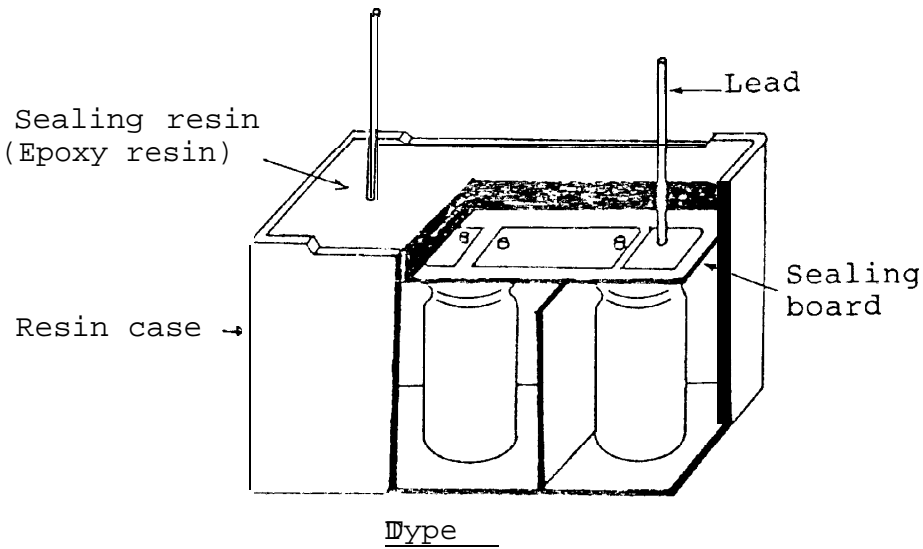

Type D

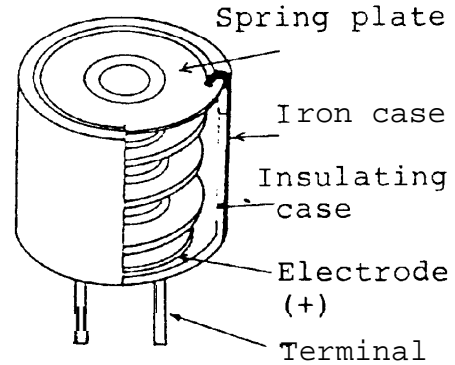

Type F

6. Practical Circuits for Golden Capacitors

(1) Basic backup circuit

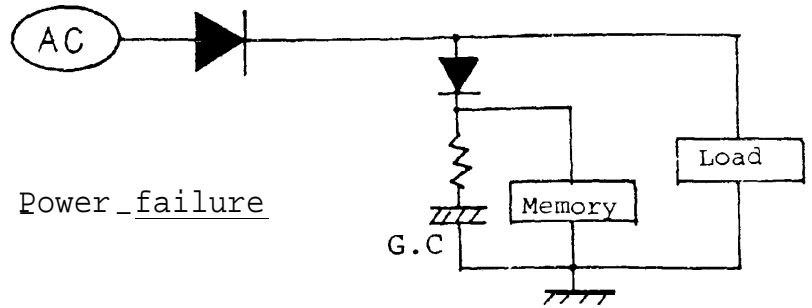

(2) Backup for a non-voltage-regulated power supply

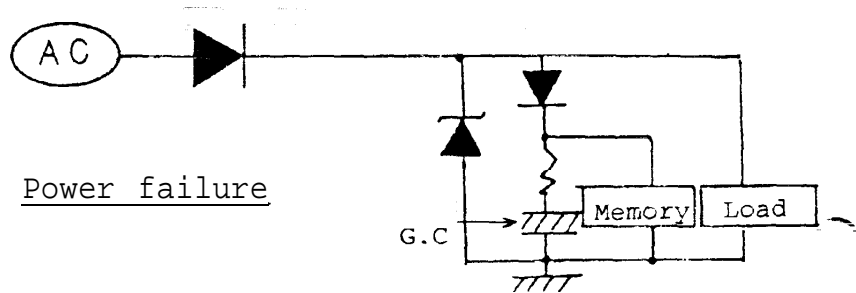

(3-1) Backup voltage differs from regular operation voltage.
(stabilized power supply)

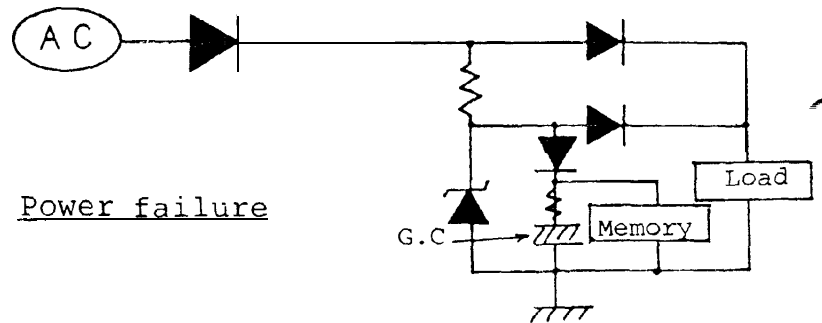

(3-2) Backup voltage differs from regular operation voltage.
(non-stabilized power supply)

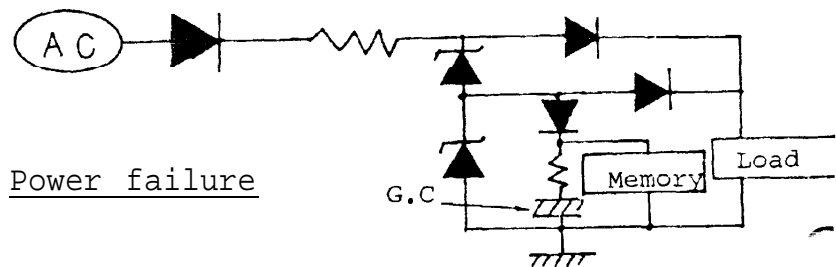

- (4) Backup for switching to emergency power supply

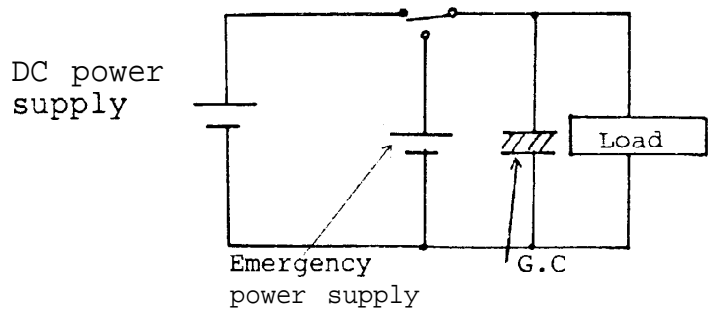

- (5) Backup against voltage drop due to momentary large control load (such as starting a motor)

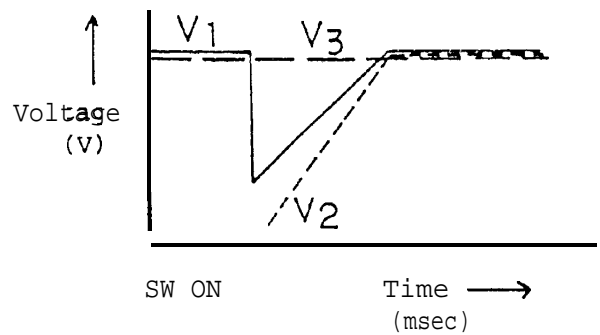
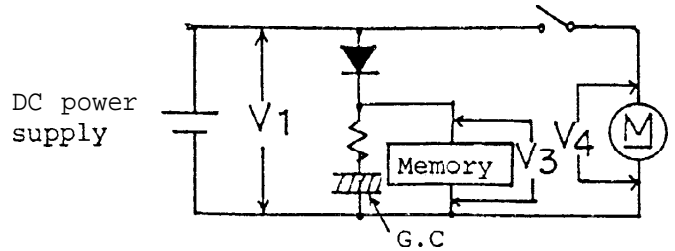

- (6) Backup for exchanging power supplies (batteries)

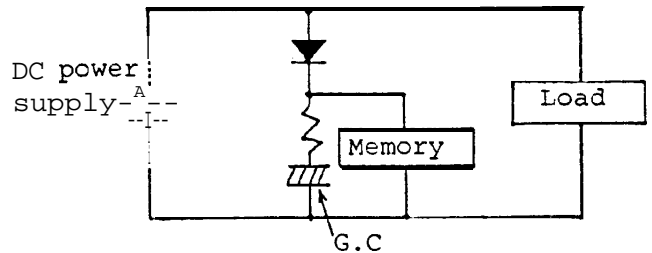

(7) Backup against unstable contact between battery and terminal (due to vibration, etc.)

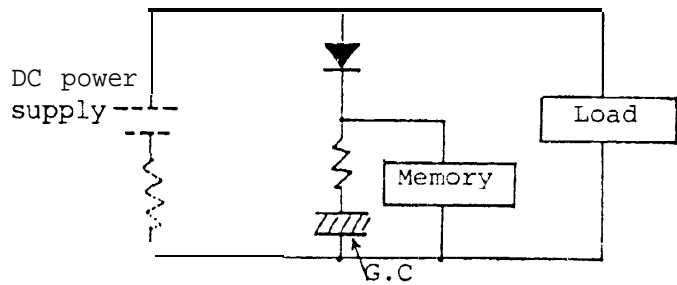

(8) Actuator drive (e.g., instantaneous holding of safety valve for gas heaters, water heaters, etc.)

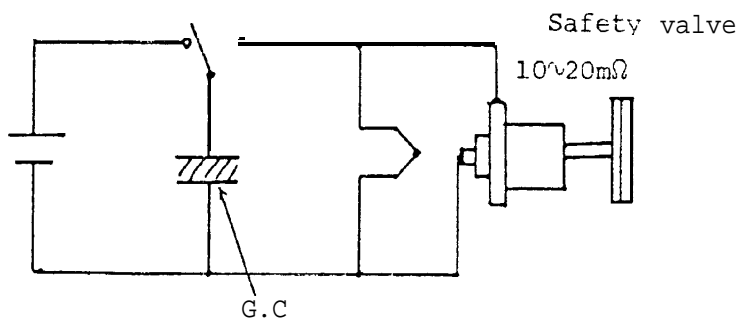

(9) Motor drive

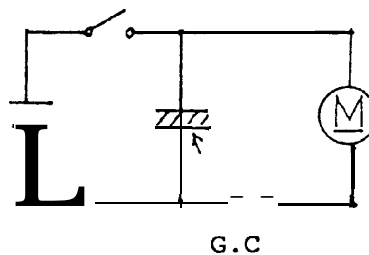

Motor can be gradually stopped when switching off.

(10) Light control

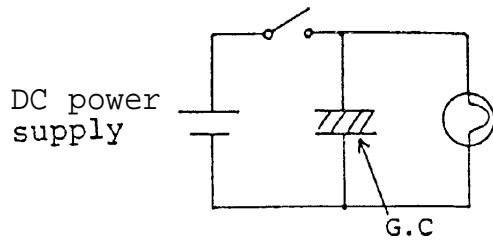

Light can be gradually faded at switching off or power failure.

(11) Auxiliary power supply for solar batteries

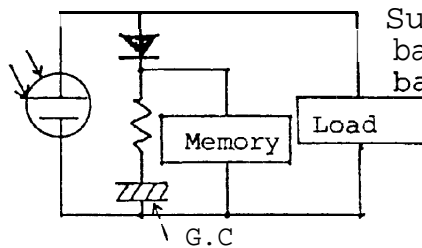

Substitute for silver battery or nickel-cadmium battery

(1) From a battery

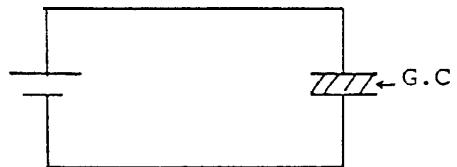

(2) From a rectifier

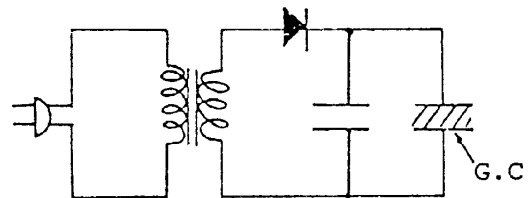

(3) From a DC dynamo

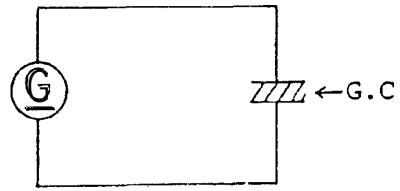

(4) From an AC dynamo

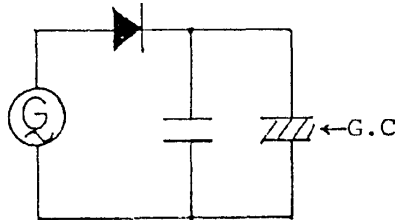

(5) From a solar battery

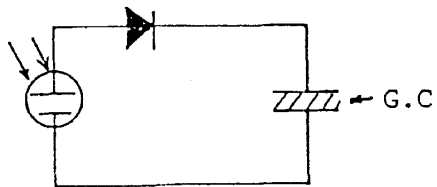

7. Equivalent Circuit Model of Gold Capacitors

Gold Capacitors, different from other conventional capacitors, use the principle of electric double layers.

A description on the equivalent circuit will be given in the following:

Fig. 1 shows the basic construction of a Gold Capacitor. The electric double layers are formed on the surface of each part of the active carbon.

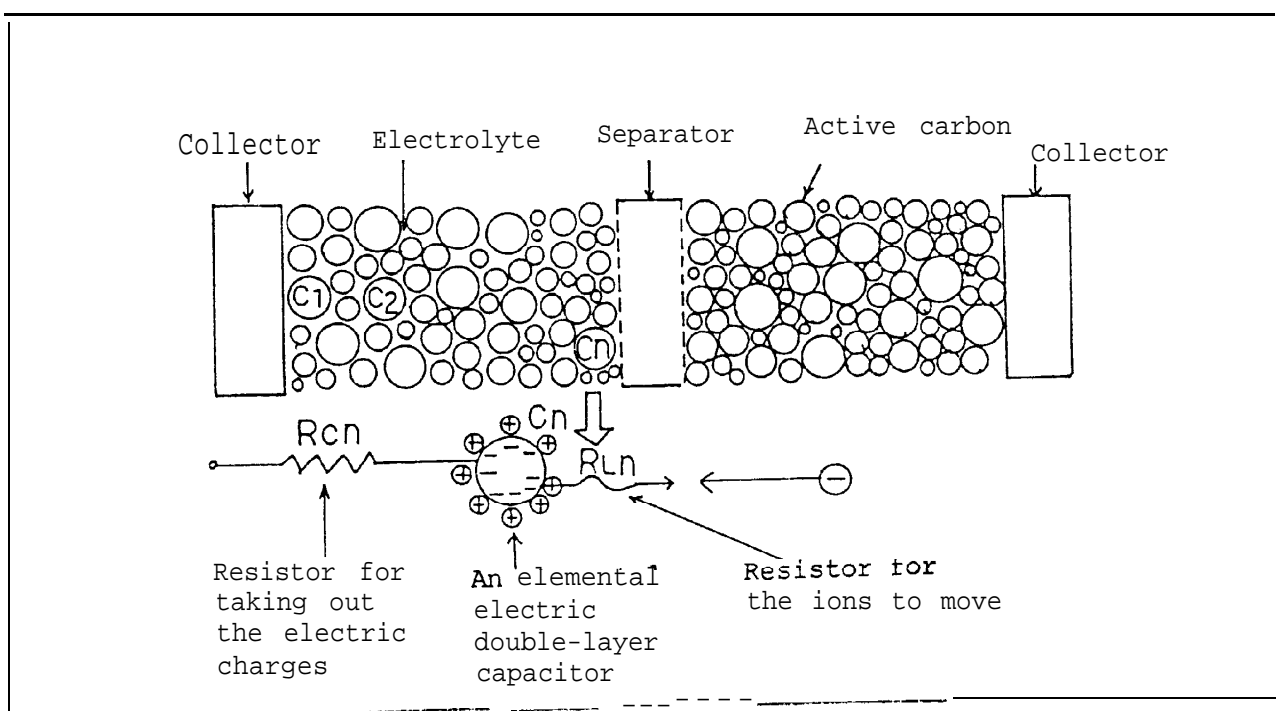

Fig. 1 Basic Construction of a Gold Capacitor and Individual Double-layer Capacitor

This part of the active carbon, for instance C_n , forms a single electric double-layer capacitor. For the internal resistance when taking the electric charge out of the electric double layers, there are two; a resistance between the active carbon C_n and the collector and a resistance relating to the transfer of the double-layer ions formed on the active carbon surface.

These resistors can take various values depending on the positional relation to the collector, the state of the binder, etc. They can be expressed as the model shown in Fig. 2. Now each part of the active carbon, having a resistance between that part of the active carbon and the collector and having a liquid resistance, is grouped, and the total capacitance is called C_n in general. The group of active carbon C_1 in Fig. 1, which is close to the collector in electric resistance, is expressed as C_1 in Fig. 2. The groups having a greater resistance than this are expressed as $C_2 C_n$.

Here, R_{cn} includes the resistance between each part of the active carbon. R_{in} is the liquid resistance of the active carbon to the separator. R_s is the liquid resistance of the separator.

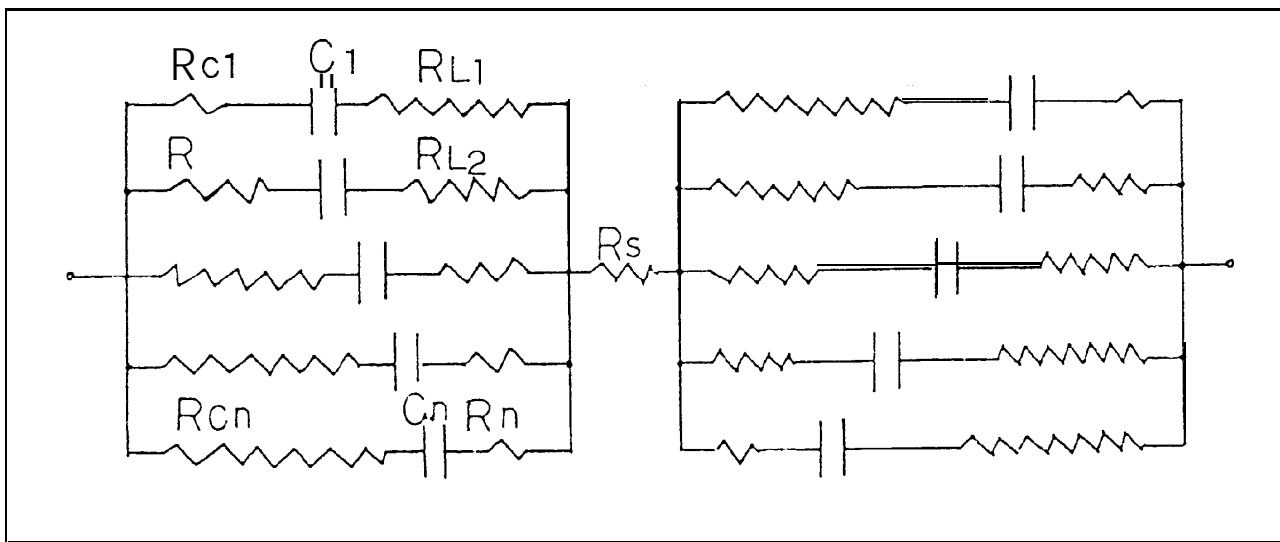

Fig. 2 Equivalent Circuit of a Gold Capacitor

C_n = Total capacitance of the active carbon
with R_{cn} and R_{in}

R_s = Separator resistance

Now an explanation will be given using Fig. 3 on the causes of the changing in R_{cn} .

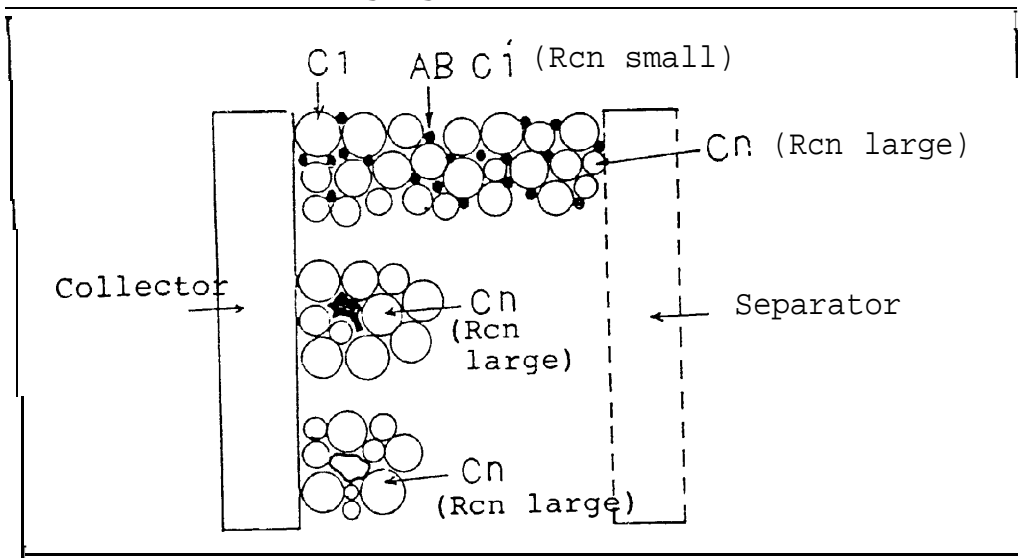

Fig. 3 State of Active Carbon and Resistance (R_{cn})
Up to Collector

R_{cn} is small for the part of the active carbon, which is in contact with the collector as shown by Cl of (a), and for the part of the active carbon as shown by Cl' whose electric conductivity to the collector is maintained by acetylene black and the like. On the other hand, R_{cn} is large for the part of the active carbon like Cn which is physically apart from the collector (influence of the thickness of the active carbon painting).

Also, as shown by Cn of (b) and (c), R_n increases when the active carbon is floating in the electrolyte or when the contact to the collector is hindered by the intermingling of a gas even when it is positioned physically close to the collector.

Regarding the liquid resistance, there are two; a liquid resistance between each part of the active carbon and a liquid resistance between the separators. When microscopically observed, even the shape of such fine holes on the active carbon surface as shown in Fig. 4 may influence the ion movement and also the temperature dependency of the apparent capacitance measured.

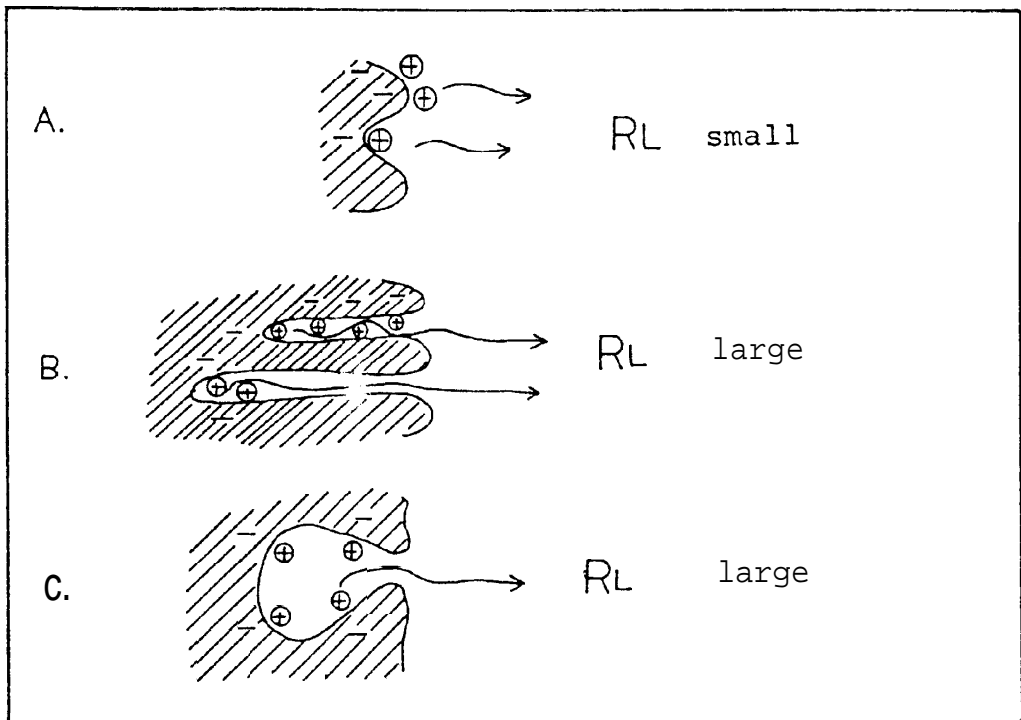

Fig. 4 Active Carbon Surface Conditions and Liquid Resistance

The equivalent circuit shown in Fig. 2 expresses the actual state of a Gold Capacitor almost correctly. However, since this circuit is complicated, a simplified equivalent circuit that can express those described above is shown in Fig. 5. According to this circuit, Gold Capacitor is considered a capacitor which consists of a parallel assembly of microcapacitors C_n having different internal resistance R_n .

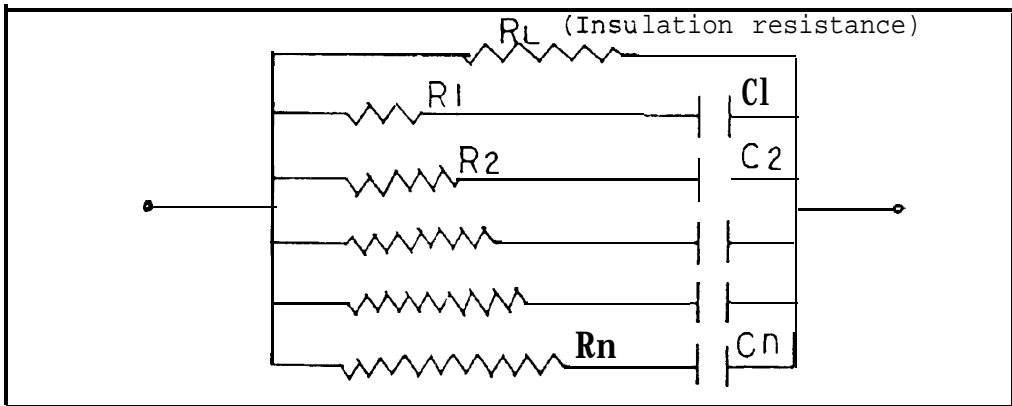

Fig. 5 Simple Equivalent Circuit of Gold Capacitor

8. Property of Capacitance

Gold Capacitors can be represented by the model shown in Fig. 5. There is large distribution in the internal resistance for the capacitance of each part of the active carbon. Some parts of the active carbon have a high internal resistance.

The electrostatic capacitance of Gold Capacitors has property similar to the electric capacity of a battery. That is, the capacitance depends on the conditions of the measurement and use, so it is considered more appropriate to be called "effective capacitance."

Influence of the measuring current

The circuit to lead a current out of a Gold Capacitor is shown in the figure below.

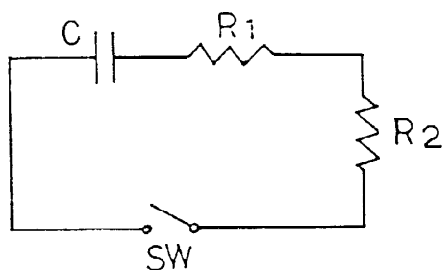

(1) Microcurrent measurement ($R_2 \gg R_1$)

When the external resistance (R_2) is greater than the resistance between each part of the active carbon R_{c1} , R_{c2} , etc., the capacitor potential at the positions of $C_1 \sim C_n$ will change almost at the same rate per time, producing no potential distribution within the capacitor electrode.

This means that the capacitance measurement for $C_1 \sim C_n$ can be made correctly when the discharging current at the measurement is very small.

(2) Large current measurement ($R_2 \ll R_1$)

When the external resistance R_2 is much smaller than the resistances between each part of the active carbons R_{c1} , R_{c2} , etc., the capacitor potential at the positions $C_1 \sim C_n$ is determined by R_{c1} , R_{c2} , etc. and therefore a potential distribution is produced within the capacitor electrode. The charges ($C_1 \rightarrow C_2 \rightarrow C_3 \rightarrow \dots$) close to the collector are so discharged that the potential between the capacitor terminals reduces quickly. Thus the measured capacitance value becomes lower.

In this case, however, the capacitance at the electric double layers is not reduced, so no

capacitance reduction is exhibited in the measurement using very small current as described above.

(This can be understood from the phenomenon that, after discharging is done by a large current and the switch is opened and as the charge within the electrode becomes uniform, the potential between the terminals is recovered.)

(3) Influence of Charging Voltage

Since Gold Capacitor is an assembly of very small capacitors with different internal resistance as shown in Fig. 5, the charging voltage will influence the measured capacitance value.

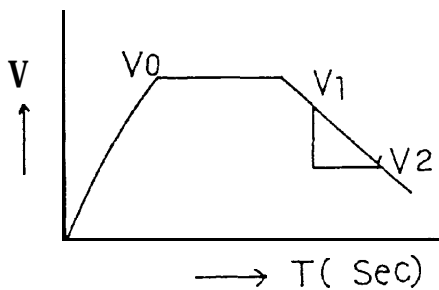

$$C = \frac{I \cdot t}{V_1 - V_2} \quad (F)$$

Fig. 6

In the case of constant-current capacitance measurement, the greater the ratio of the applied voltage (V_0) to the capacitance measuring voltage ($V_1 \sim V_2$) in Fig. 6 is, that is, the greater the

difference between the microcapacitor voltage and the measuring voltage is, and the longer the charging period is, the greater the measured capacitance value will be because charging will proceed to the microcapacitors which are apart from the collector and therefore more charges can be gained.

(4) Influence of Leakage Current

In the capacitance measuring conditions, leakage current that influences the measurement consists of the electronic conductive current (i_B) and the current (i_C) which is consumed by charging the non-charged portion.

When a Gold Capacitor with such currents is measured at a constant current (i), the measured capacitance (C) is determined from the following equation (1):

$$C = \frac{(i - i_B - i_C)t}{\Delta E} \text{ ----(1)}$$

t : Measuring period
 ΔE : Measuring voltage difference (V)

When the low current measurement is used in order to correctly measure the capacitance of Gold Capacitors, care should be taken of the setting of the current value because its influence on the measurement cannot be neglected.

(5) Influence of High Temperature Load Test

The capacitance value measured after performing a high temperature load test will be lower than that prior to the test. This is because the resistance between each part of the active carbon increases and the measurement is taken with constant current using a large current.

In this case, therefore, a higher value will be obtained when the current is reduced, because sufficient charges can be taken from the **micro-**capacitors which are apart from the collector and have higher internal resistance.

9. Leakage Current

The leakage current of Gold Capacitors consists of the following 2 items:

1. Leakage due to the electronic conductive material existing between the + and - electrodes.
2. Insulation resistance of the electrolyte

In the Product Standard of Gold capacitors, the leakage current is specified as the value measured 60 minutes after the voltage application for the reason of the measuring period. This charging period, however, is not adequate to obtain the true leakage current because the measured value includes the charging current for the active carbon which is apart from the collector and has large resistance.

This indicates that the leakage current value obtained by the present measuring method does not give correct self-discharging current at the time when Gold Capacitors are left to stand at no load. The measured value should, therefore, be used only for reference.

(1) Influence of High Temperature Load Test

The leakage current is, as described above, the sum of the electronic conductive leakage current, the leakage current due to the insulation resistance of

the electrolyte, and the charging current at the initial stage.

Before the test, since the collectivity from the active carbon is good, the charging current which is initially large reduces rapidly as shown by Curve 1 in the following graph. After the high temperature load test, however, (discharging and recharging are performed before measuring the leakage current) the leakage current curve becomes as shown by Curve 2. This is because the resistance between each part of the active carbon increases as described above and a longer period of time is required for charging.

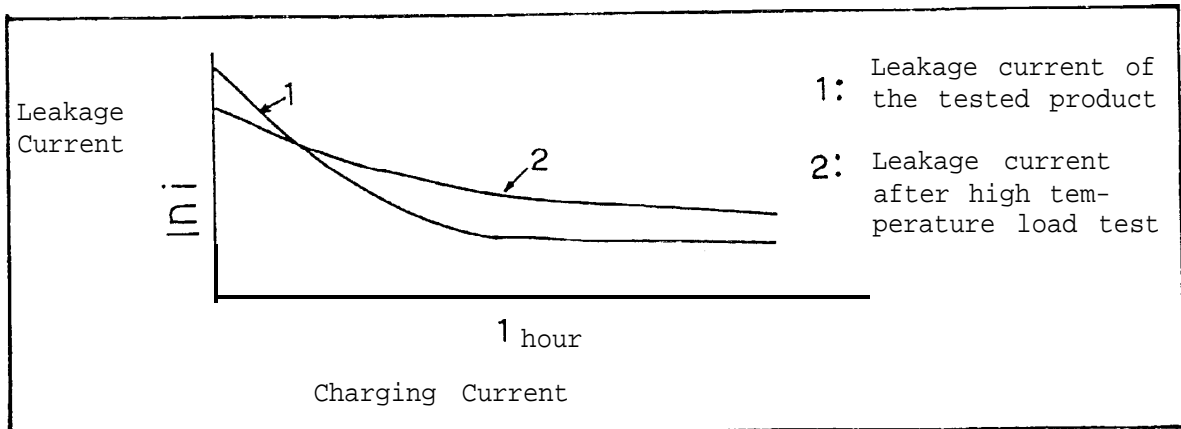

10. Voltage Holding Characteristic

When Gold Capacitor is charged until a constant voltage is reached and left to stand at no load, the following are considered to be the causes of self-discharging:

1. Voltage drop caused by the leakage discharge due to the electronic conductive material existing between the + and - electrodes.
2. Voltage drop caused by the insulation resistance of the electrolyte.
3. Voltage drop caused by self-charging the non-discharged portion within the electrode.

(1) Voltage drop caused by electric conductive material

When electric conductive material is existing between the electrodes, the change in charge Q within the capacitor, can be expressed by equation (2) as follows:

$$Q = Q_0 \exp(-t/CR) \text{-----(2)}$$

where

R = Electric conductive resistance

Since the voltage dependency is small in the capacitance of this capacitor, it is considered $V \approx kQ$, the change in voltage according to time is expressed by equation (3).

$$V = Q_0 \exp(-t/CR) \text{-----(3)}$$

(2) Voltage drop caused by self-charging the non-charged portion

This phenomenon occurs because there is active carbon within the electrode which has high resistance from the capacitor, as described in the paragraph for capacitance.

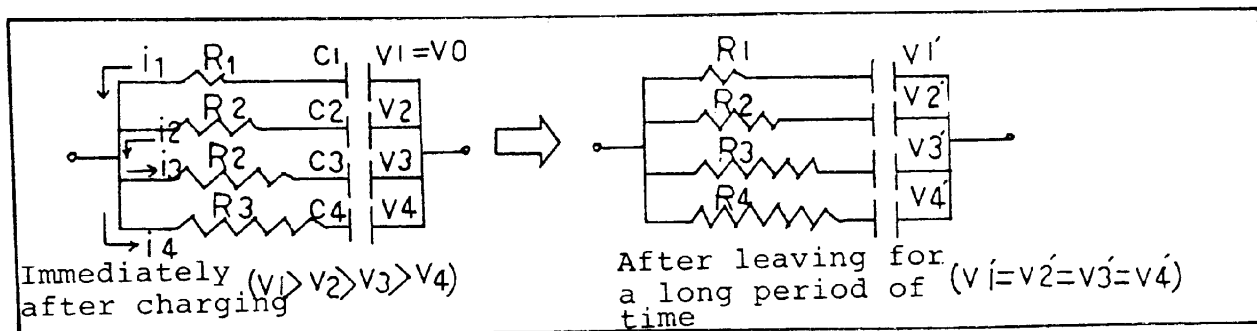

Fig. 7 Self-charging within the electrode

That is, electric charges move from the active carbon charged within the electrode to the non-charged active carbon, causing a reduction in the charges near the collector and a drop in the terminal voltage.

A detailed explanation will be given in the following using Fig. 7. After a certain period of charging, the active carbon of capacitance C1, which has low internal resistance R1 will be charged soon to reach the applied voltage Vo. However, the charging voltage for C3 and C4 with high resistance will increase according to the following equation, so the charging will be delayed, reaching V3 and V4 which are lower than Vo.

$$V = V_0(1 - \exp(-t/RC))$$

When the charging is stopped, self-discharging occurs within the electrode from C1, C2, etc. of higher voltage to C3, C4, etc. because of the voltage difference until reaching voltages V1' ~ V4' which is determined by each capacitance and amount of charge. This is the phenomenon which occurs within a single electrode of + pole and - pole.

- (3) Voltage drop caused by self-charging, and complete charging period

The voltage drop occurs at the initial stage as shown in Fig. 8. The hatched area over the extension of the straight line portion corresponds to the voltage drop caused by the self-charging of the non-charged portion.

The voltage drop can be determined as the difference between initial voltage V_0 and voltage V_2 which is at the intersection of the extension of the straight line and the vertical axis at $t = 0$.

This voltage drop depends on the charging period.

No voltage drop occurs when the charging is completed.

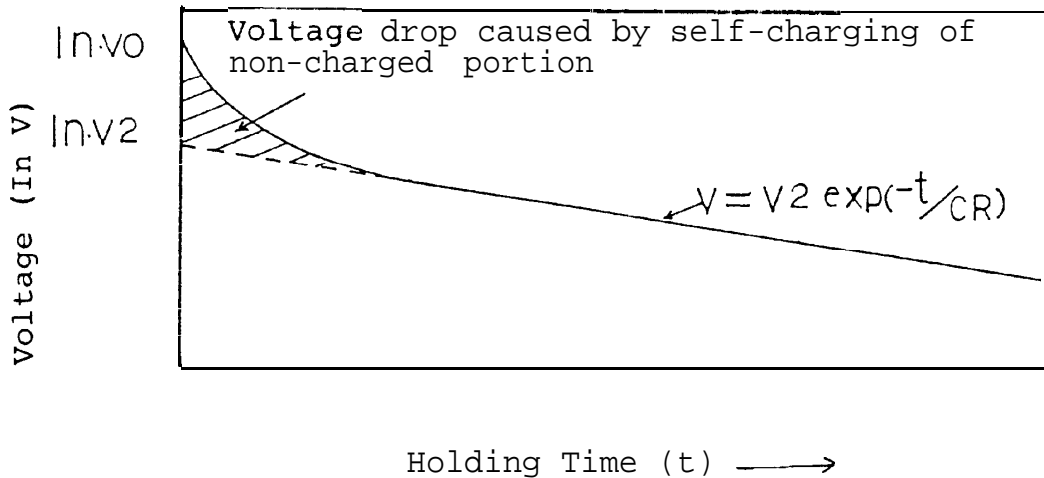

Fig. 8 Voltage Holding Characteristic