

**Wireless RF Transceiver
433MHzFSK Data Transfer
User's Guide**

Table of contents

Chapter1. Specifications of 433MHz module for transmitting and receiving wireless data.....	1
Chapter2. Contact Us	8

Wireless RF Transceiver 433MHz FSK

NOTES:

Product Version : Ver 1.0

Document Version : Ver 1.0

Chapter1. Specifications of 433MHz module for transmitting and receiving wireless data

Specifications of 433MHz module for transmitting and receiving wireless data

433MHz is an integrative module for transmitting and receiving wireless data based on FSK Zero-IF digital infrastructure. The products conform to related laws and standards about micro-power wireless telecommunication devices in PRC, USA, Canada, EU, Australia, New Zealand, etc. This module is sorted as version A and B based on the firmware program employed. The difference of these two versions lies on the conditions of activation for data transmission and the way that transmitting and receiving status are switched while the radio frequency performance and functions of both versions remain consistent. You may refer to the following for details:

Pin Definition:

The pin started from the left side (viewed from the side that IC components are visible) is pin 1. Please pay close attention that the pins on module PCB have been marked with pin 1 and pin 8.

PIN1: VCC. +2.4V~+4.2v, requires at least 100mA stable current supply, the ripple shall be reduced to the amount of less than 20mv while the interface of power supply shall be equipped with appropriate decoupling components.

PIN2 :GND

PIN3: RXD. Serial input, baud rate 19200 (customizable), 8-bit data bits, 1-bit start bit, 1-bit stop bit. This IO is input.

PIN4: TXD. Serial output, baud rate 19200 (customizable), 8-bit data bits, 1-bit start bit, 1-bit stop bit. This IO is input.

PIN5: Enable. This is "Enable" port of module, active low. This IO is input.

PIN6: Busy. It output "busy" signal during transmission and receiving, active low. This IO is output.

Specifications of 433MHz module for transmitting and receiving wireless data

PIN 7: for module of 433MHz type, this pin is reserved. This IO is input.

PIN 8: Frequency Setting Enable Port, active low. This IO is input.

Notes:

The interface level of this module conforms to 3V TTL standard. Therefore the level must be converted before it can be connected with RS232 interface of PC. Both interfaces can be directly interconnected if the IO of high logic that connected with the module's interface is "weak pull-up" type (like standard IO of MCU) when the module is used in a 5v system and supplied with low voltage. However, if the IO on high voltage side is "strong pull-up" type (like the output of 74HC chip and output of 232 chip empowered by 5v supply), level conversion must be carried out before connection. A simple solution is to insert a 1k resistor between IO of 5v logic and 3v logic. Those unused output pins of the module must be suspended and unused input pins and "reserved" pins may remain suspended or pulled up by resistor to VCC. The upper rated voltage of module 433MHzFSK is 4.2v, if exceeded (e.g. 5v input), potential instability might be occurring, or malfunction might take place and even endanger the module, so it is not recommended to put this module directly into a 5v system.

How to use this module:

Firstly, make sure the Enable Port PIN5 is maintained as low level.

PIN8 must be maintained as high level or suspended during data transmission and reception.

Data Reception:

When valid data has been received by the module, demodulated data will be transmitted serially from TXD automatically. Busy port maintains low level during data frame transmission, and turns into high when data frame transmission has been finished or no valid data has been received.

Data Transmission:

Module of 433MHz type:

When the level of "Busy" indicates high, data could be directly feed into RXD terminal in standard serial communication format in series. The module will automatically switch into transmission status if the data input stops for approximately 10 ms long. In programming application, please stop for at least 15 ms.

Specifications of 433MHz module for transmitting and receiving wireless data

During data transmission, “Busy” output remains low level, so please don’t use serial port for data transmission. Otherwise, it will be processed as invalid. When “Busy” indicator is not in use, appropriate delay might be added prior to the transmission of the next frame data after the transmission of the previous frame data is finished.

This module supports both transmission and reception of any hex data including ASCII characters, Chinese character, etc. The data amount of single frame for this module is limited into a threshold of 1byte~64 bytes. Any data that beyond this range will be ignored.

“Busy” output is “strong pull-down” type which could bear a maximum current of up to 20mA. It is allowed to insert LED and current-limiting resistor as indicator for data transmission and reception between “Busy” port and VCC.

Frequency Settings

PIN 8 shall remain low level during frequency settings.

The frequency settings of module can proceed during either data transmission or reception.

It accepts 64 frequencies on this module and numbered from channel 0~63. The setting parameter is “not so easily lost on power down”. Over 100,000 operations shall be guaranteed, the frequency that the module is working on next time shall be subject to the settings of last time. Set PIN8 to low level when the working frequency is to be set, then, feed hex command “0xaf” and channel number continuously from serial port, the channel number ranges from 0-63 in decimal (corresponding to 0x00-0x3f in hex). Numbers input that exceed 63 will automatically be modified as 63. The results of frequency setting will be returned from serial port which serves as the basis of valid operation. After the frequency setting parameters are feed into serial port of module, PIN 6 (Busy) will indicate as low level and will resume to high level after setting is finished. Setting PIN8 to high level after the frequency settings been finished (you may monitor Busy indication) will lead you to the new status of data transmission and reception on newly-selected frequency.

Frequency settings on each channel are shown as follows:

433M: 430.26M-439.71M

868M: 860.50M-869.95M

915M: 915.18M-924.63M

The difference between channels is 150 kHz, detailed channel frequency calculation (take 915M channel as an example, other frequency settings have the same calculation method

Specifications of 433MHz module for transmitting and receiving wireless data

but different initial frequency): $f=915.18+\text{channel number} \times 0.15$ in MHz.

The above-mentioned frequency settings have dodged internal CDMA and GSM frequency band, for export products, more frequencies can be provided for selection in accordance with related standard of countries in which products with this module are going to be sold.

Standby Operation for Ultra-low Power Consumption

To switch the module to a standby status that consumes extremely low power, just keep Enable port PIN5 high, regardless of the present status of module as in either data transmission or reception. At this moment, the standby current of this module will be reduced to an amount of less than $1\mu\text{A}$. Notes that in order to ensure low power consumption at standby status, all IO pins shall be suspended or connected to high level that has equivalent level with the power supply of this module, otherwise, "potential current" will leak from module IO. Even the potential current is extremely low (about μA), but this consumption would be far beyond the entire power consumption.

Set Enable port PIN5 to low level for stepping out from standby status. It may take a while from standby to regular running status. For 433MHzFSK-A, it would always be in a reception status when awakened.

Connect Enable port PIN5 to ground directly for not using the standby function.

Notes: if PIN5 is set as high level during frequency settings, you will have to wait for the accomplishment of frequency settings before entering into standby.

The following figure is the testing circuit diagram in which 433MHzFSK is connected with serial port of PC. This PC provides a platform on which any serial port debugging software can be used for the testing of data transmission and reception and frequency settings. Switch K1 in this figure is used for the switch of data transmission and reception (433MHzFSK-A doesn't need this switch), switch K2 is used for frequency selection. This testing circuit adopts double power supplies, VDD is 5v, and VCC is 3.3v, which can be available by a piece of 3.3v LDO from VDD.

Specifications of 433MHz module for transmitting and receiving wireless data

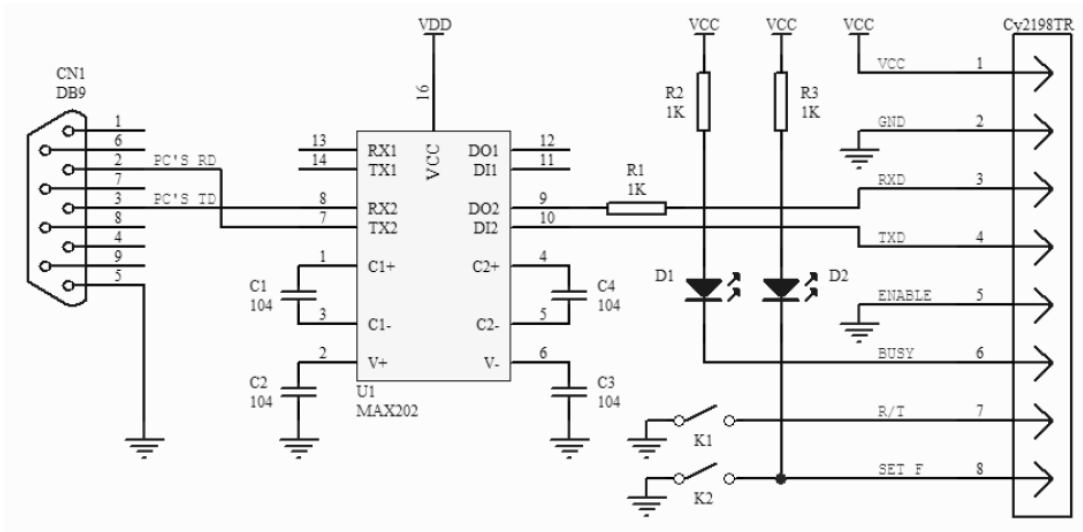

The following figure shows the connection of module and MCU in which PIN5, PIN6, PIN8 are optional connection. For 433MHzFSK-A, it's unnecessary to connect PIN7, grounding PIN5 directly if ultra low consumption is not in use. Notes that "Busy Port" PIN6 cannot be pulled up directly to power supply. Otherwise, module might be endangered and even damage to peripheral circuit or power supply. It is recommended to use LDO of 3.3v output like 1117-330 when this module is in a 5v application, output and input port of LDO chip should be parallel connected with a Polarized Capacitor at least 100 μ F to GND, low-capacity tantalum capacitor is ideal for the output filter capacitor for LDO.

Specifications of 433MHz module for transmitting and receiving wireless data

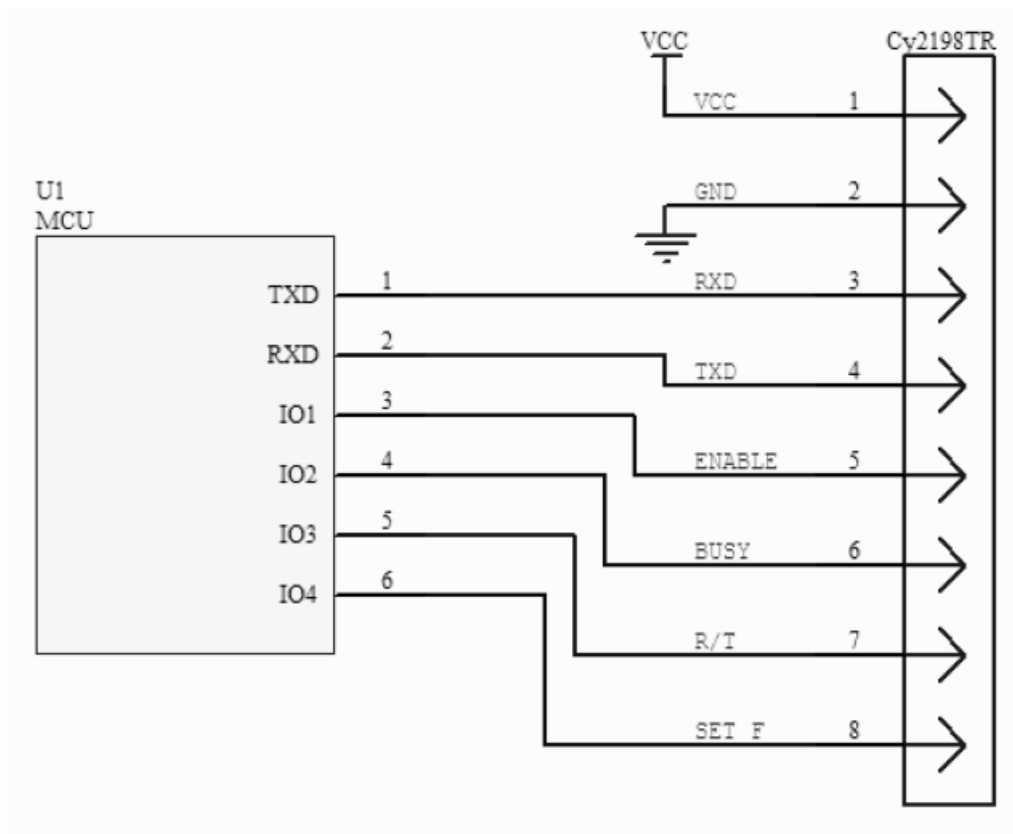

Special Attention:

Since the performance of voltage ascending slope that the radio frequency chip of this module requires is too high when power supply is connected, something unwanted like PLL locking tolerance which causes communication failure may happen when some LDO chips of low adjustment rate are used or some bigger filter capacitors are exist in circuit. The solution to this problem is to replace with another type of LDO of high adjustment rate and arrange filter capacitors of bigger capacity at the input side of LDO and try not to arrange big-capacity capacitors at the output side. You may also attach another circuit as shown in the following figure. This circuit is applicable to all power supplies.

Specifications of 433MHz module for transmitting and receiving wireless data

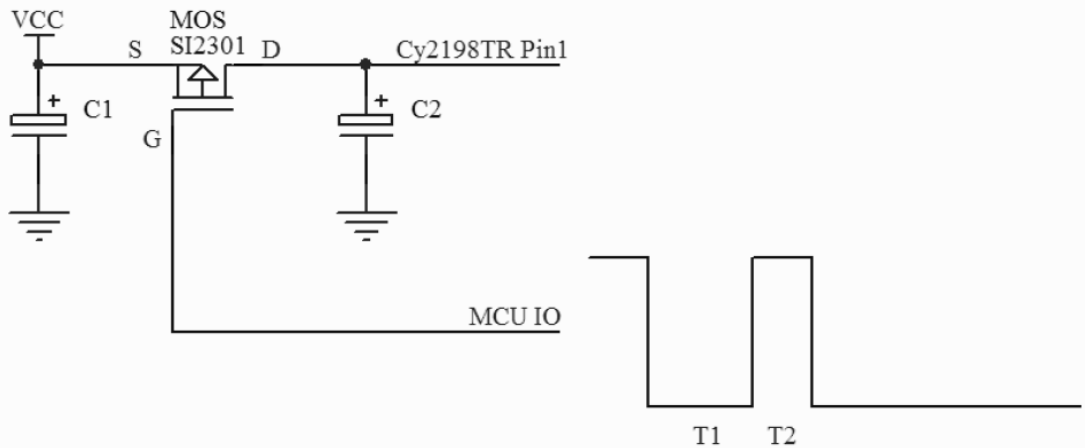

This circuit requires an IO port of microcontroller (MCU) to turn on and off a MOS transistor. T1 indicates a charging cycle that normally takes hundreds ms or longer. T2 is release cycle that determined by the capacity of filter capacitor in the circuit. Larger capacity requires longer release time, normally around 200ms, and this parameter had better to be got by a test. It is recommended to use P-channel MOS transistor like SI2301, etc or PNP transistor as a switch tube of power supply. However, it requires sufficient base current to guarantee saturation connection for transistor.

Chapter2. Contact Us

Sure Electronics Co., Ltd.

5F, Zone A,

Qinhuai Technology Innovation Center

105-2 DaMing Rd(Zip Code : 210022)

Nanjing

PRC

Tel: +86-25-66606340 (English Service) GMT1am-10am

Fax: +86-25-66606346

Website: www.sure-electronics.net

www.sureelectronics.net

www.sure-electronics.com